

INSULATION RETROFIT  
DESIGN

Issued for Comment

**ENERGY SOLUTIONS CENTRE**

**YUKON GOVERNMENT**

**MAY 2009**

prepared by

**N. A. JACOBSEN, P.Eng.**

CIVIL ENGINEERING CONSULTANT

Whitehorse, Yukon

## TABLE OF CONTENTS

1.0 INTRODUCTION .....	1
2.0 ASSESSMENT AND DISCUSSION .....	
2.1 Eave Extension Support Systems .....	
2.2 Stand-off Support Systems .....	
APPENDIX A: Specifications .....	
APPENDIX B: Insulation Retrofit Drawings	
• Standard Drawings for Homes with Minimum 20” Eaves	
Fig. 1 of 8 Typical Section	
Fig. 2 of 8 Base Details Above Grade	
Fig. 3 of 8 Base Details Below Grade	
Fig. 4 of 8 Sections	
Fig. 5 of 8 Gable End Section and Framing Support Around Window	
Fig. 6 of 8 Window Exterior Section and Floating Exterior Corner	
• Standard Drawings for 3- and 4-Storey Buildings	
Fig. 7 of 8 Typical Section	
Fig. 8 of 8 Alternate Standoff Support Using Ledger and Alternative Gable End Support	

## 1.0 INTRODUCTION

Following is a structural assessment of a support system for an insulation retrofit design that may be used for existing buildings of varying height and construction. The intent is to provide an efficient design and one that reduces the amount of wood framing to less than half of the framing required for a Larsen truss.

The structural assessment considers various conditions which may occur when installing the support system on the outside face of a building. From the assessment, recommendations are presented which include limitations and guidelines for the application of the design.

The appendix includes specifications and standard details for construction of the insulation retrofit which may be used as part of a tender package.

## 2.0 ASSESSMENT AND DISCUSSION

Two support systems were considered in this project.

The key feature of the first system is its reliance on the tail ends of the roof truss extension or rafters to support the framework. This is different from the support system used for the Larsen truss which relies on a cantilevered bottom support extension from under the floor joists, or by direct connection of the truss to joists and joist headers. With the proposed system, the amount of material is reduced because there is no need for framing next to the wall, with support being provided by the roof overhang and a spacer at the bottom end. Details are shown on the drawings in Appendix B.

The second system relies on stand-offs connected to structural components of the building to support the framework. This system is suited to buildings that do not have roof truss extensions or rafters for support. This method is also best suited for 3- and 4-storey buildings and for other types of building construction including masonry and concrete. Details are shown on drawings in Appendix B.

Assessment and discussion on the structural components of each system are as follows.

## 2.1 Eave Extension Support Systems

### Connection at Roof Extension

The typical roof overhang will consist of the tail ends of the top chords of trusses, the bottom chords of truss extensions, or rafters. The drawings show a typical top chord extension. The gable end of the building will normally have a ladder extension, which is tied back to the roof trusses.

The truss or rafter tails were assessed for shear and moment resistance under a variety of conditions and assumptions as follows:

- It was assumed that the cantilevered members used for support would be either 2x6 or 2x4 lumber, SPF (Spruce-Pine-Fir) No. 2 or better quality, and in sound condition with no deterioration or damage.
- The review considered tail extensions at 16" and 24" o.c. Gable end ladder extensions are normally spaced at 24" o.c.
- The gravity load on the tail extensions was calculated based on the following materials:
  - 2x4 vertical members at both 16" and 24" spacing
  - ROXUL Flexibatt insulation at 2 lb/ft<sup>3</sup> density
  - 3/8" plywood sheathing
  - Hardiboard cladding
  - bottom spacers and plywood cover
  - miscellaneous framing and hardware

It is noted that most of the weight is contributed by the insulation and the plywood. Based on a 10' height of retrofit, the gravity load will be close to 50 plf. (pounds per lineal foot) The loading correspondingly increases with wall height.

Not surprisingly, the structural review found that the limiting factor at the top connection will be the shear capacity of the tail extension. It was found that 2x6 members will be adequate for most conditions including retrofit heights to 25' and to support increased loads on the sides of window openings up to 8' wide. However, there will be some limitations with the use of 2x4 tail extensions for support. If the 2x4 members are all of good quality and in good condition, they may be adequate to support a retrofit height of up to 20'. However, there will be limitations to the width of wall openings requiring support. Guidelines for the various applications are included in the specifications.

A nailing schedule for connection of the 2x4 upright to the tail extension is provided in the specifications. Where loading is increased due to increased retrofit height or framing around

windows, connectors such as the Simpson Strong Tie A35 framing angle are recommended, rather than nailing by itself.

### Framing Around Windows

When framing around windows, the two uprights on each side of the opening will potentially carry some increased load from the window extension support plus the retrofit below the window. Construction details for the support system are shown on the drawings, including framing connectors and additional 2x6 between the uprights to support the window frame extension.

The assessment indicates that there will be limitations to the allowable width of the openings using support from two side studs. If the tail extensions are not capable of supporting the loads from framing around a large opening, then an alternate means of support can be used by hanging the framework from the tail extensions above the opening.

The specifications provide guidelines relating to support of framed openings.

### Gable End Conditions

Where the uprights are connected to ladder extensions, the retrofit weight will result in an increased uplift force at the truss top chord connection. Since there is some uncertainty regarding the adequacy of this connection, it is recommended that it be upgraded with an SST (Simpson Strong Tie) A35 framing angle, point installed as indicated, to ensure that there will be adequate restraint at this connection.

### Wind Loading

The Building Code does not provide guidelines for allowable deflections in this type of wall structure. However, it is recommended that in order to ensure stability and avoid excessive deflection from winds or other lateral forces, some guidelines be provided. For example, a structural review indicates that 2x4 uprights at 24" o.c. having a 10' height will deflect about 1" under a 1/50 hourly wind pressure load of 8 psf (pounds per square foot) as per 2005 NBC (National Building Code of Canada) plus a gust factor of 2. Based on a general review, I suggest that intermediate stand-off supports be provided where the stud height exceeds 10' for 24" stud spacing, and 15' where the studs are at 16" o.c.

### Building Height

The specifications for this type of support system apply only to buildings up to two storeys in height. In most cases, the supports can be designed to accommodate the loads imposed by a retrofit system covering a 2-storey high wall, including the higher gable ends. However, alternative design details should be considered for wall systems higher than two storeys. It is recommended that intermediate stand-off supports be required for two-storey projects in addition

to a stronger connection detail at the tail extension such as SST A35 framing angles as noted on the drawings.

### Framing Close to Ground Level

For some installations, it may be desirable to extend the retrofit close to ground surface, in order to maximize the wall coverage. However, PWF materials should be used when structures are close to the ground surface in order to prevent decay or deterioration of the wood components. The 2005 NBC provides some guidance on this matter as follows:

- Section 9.3.2.9.1 specifies an 18” clearance requirement between (non-PWF) structural wood elements and the finished ground level in localities where termites are known to occur.
- Section 9.3.2.9.3 states that structural wood elements are required to be pressure-treated where the vertical clearance to finished ground level is less than 6”.
- Section 9.2.7.2.4 states that a clearance of not less than 8” shall be provided between finished ground and cladding that is adversely affected by moisture such as untreated wood, plywood, OSB, wafer board and hardboard.

Based on the above, it appears that 8” is the absolute minimum clearance required assuming that termites are not an issue. Termite damage to building structures is not considered to be a common problem in the Yukon and, as such, the 18” clearance requirement may be somewhat excessive. The 8” clearance in Section 9.2.7.2.4 could therefore be considered the minimum requirement. However, it is suggested that the clearance be increased to 12”, to allow for changes in ground elevation, vegetative growth, additional soil cover, etc. that could potentially occur under or close to the bottom of the retrofit in the future.

In order to allow for this condition, details have been developed which include PWF materials in the lower portion of the support framework where the clearance is less than 12”. It is recommended that at least 2” vertical clearance to finished ground be provided to allow for seasonal ground movement and to avoid direct contact with the ground. Contact with ground must be avoided since this could cause distress in the support framework and connections.

## **2.2 Stand-off Support Systems**

With this support system, the framework is supported by stand-offs, which are connected to a continuous ledger into headers at floor level or into wall studs. Typical details are shown on Sheets 7 and 8. Typically, the stand-offs should be provided at floor level and also require a top connection.

### Framing Around Windows

Standard framing techniques as per Part 9 of the NBC can normally be used for framing around windows in non load-bearing walls.

### Framework

Wood or steel studs may be used for the framework. Typically, 2x4 uprights would be used, spaced at 16" or 24" o.c. Steel studs may be a preferred option in 2-or 3-storey retrofit conditions where long continuous stud lengths may be employed. They also have the advantage of being lighter in weight and have a more consistent and straight profile than wood. Stud sizes and spacings are provided in the specifications.

Other details such as framing close to ground level have been discussed in the previous section.

N. A. Jacobsen, P.Eng.  
Civil Engineering Consultant

## APPENDIX A

### **Specifications**

Issued for Comment



**PART 1 – GENERAL**

- 1.1 Description** .1 This specification refers to the supply of all materials, equipment, labour, and supervision for the construction of insulation retrofit systems as described herein and on the attached drawings.
- 1.2 Alternate Materials or Methods** .1 Requests for the use of alternate materials or methods of construction shall be made in writing to the Owner for approval.
- 1.3 Products** .1 All products, equipment and articles incorporated into the work shall be new, not damaged, and of a grade compatible with the specifications for the purposes intended.
- 1.4 Workmanship** .1 Workmanship shall be of acceptable quality executed by workers experienced in their respective trades.
- 1.5 Quality Control** .1 The framework must be inspected and approved by the Owner prior to installing the insulation and sheathing.  
.2 Provide at least 45 hours' prior notice.  
.3 If the Contractor covers or permits to be covered any work that is subject to inspection, the Contractor shall uncover the work, have the inspections satisfactorily completed, and make good the work at his own expense.
- 1.6 Construction** .1 All construction is to conform to the latest edition of the National Building Code of Canada.
- 1.7 References** .1 Canadian Standards Association (CSA International)  
.1 CSA B111-1974(R1998), Wire Nails, Spikes and Staples.  
.2 CAN/CSA-G164-M92(R1998), Hot Dip Galvanizing of Irregularly Shaped Articles.  
.3 CSA O121-M1978(R1998), Douglas Fir Plywood.  
.4 CAN/CSA-O141-91(R1999), Softwood Lumber.  
.5 CSA O151-M1978(R1998), Canadian Softwood Plywood.  
.6 CAN/CSA-O325.0-92(R1998), Construction Sheathing.  
.7 CAN/CSA-S406-92 (R1998), Preserved Wood Foundations  
.2 National Lumber Grades Authority (NLGA)  
.1 Standard Grading Rules for Canadian Lumber 2000.
- 1.8 Quality Assurance** .1 Lumber identification: by grade stamp of an agency certified by Canadian Lumber Standards Accreditation Board.

- .2 Plywood identification: by grade mark in accordance with applicable CSA standards.
- .3 Plywood sheathing identification: by grade mark in accordance with applicable CSA standards.

## **PART 2 – PRODUCTS**

### **2.1 Lumber Material**

- .1 Lumber: unless specified otherwise, softwood, S4S, moisture content 19% or less in accordance with following standards:
  - .1 CAN/CSA-O141.
  - .2 NLGA Standard Grading Rules for Canadian Lumber.
- .2 Furring, blocking, nailing strips, grounds, rough bucks, cants, curbs, fascia backing and sleepers:
  - .1 Board sizes: No. 2 or better grade.
  - .2 Dimension sizes: No. 2 or better grade.

### **2.2 Steel Studs**

- .1 Steel: to CAN/CSA-S136, fabricated from ASTM A446M, Grade A to D steel, zinc-coated (galvanized) by the hot-dip process.

### **2.3 Panel Materials**

- .1 Canadian softwood plywood (CSP): to CSA O151, standard construction.
  - .1 3/8" exterior walls
  - .2 1/2" bottom of retrofit
- .2 Pressure-treated lumber and plywood for base of retrofit where required to CSA 080, Series M89 and CSA 080.15-M.

### **2.4 Accessories**

- .1 Nails, spikes and staples: to CSA B111.
- .2 Bolts: 12.5 mm (1/2") diameter unless indicated otherwise, complete with nuts and washers.

### **2.5 Finishes**

- .1 Galvanizing: to CAN/CSA-G164, use galvanized fasteners for exterior work interior highly humid areas and pressure- preservative treated lumber.

### **2.6 Air Barrier**

- .1 Polyethylene film: 6 mil throughout.

### **2.7 Insulation**

- .1 Mineral wool, semi-rigid batt insulation Roxul "Flexibatt" R22 or approved alternate.
- .2 Two layers of R22 insulation are required to provide a total of R44 insulation value.

- .3 Supply the batts to the required stud width dimension.

**2.8 Cladding**

- .1 Hardiboard or as approved by the Owner.

**PART 3 – EXECUTION**

**3.1 Air Barrier**

- .1 Attach poly air barrier to face of building using acoustical sealant and staples.
- .2 Overlap all joints by 6” and seal with acoustical sealant.

**3.2 Framing**

- .1 Attach bucks and wood supports to house framing components to provide secure attachments as indicated.
- .2 Attach studs to overhang members as indicated and align vertically to a tolerance of 1:600.
- .3 After all of the framing is completed, including the base support and stand-offs, the work must be inspected and approved by the Owner prior to installing the installation.
- .4 Window Openings: The framing detail around window openings as shown on the drawings may be used within certain limits. Following are maximum allowable heights of retrofit wall that may be supported for two sizes and spacings of rafter/truss tails, and for three opening widths;
- .1 4’ WIDE OPENING
- 2x4 @ 24” o/c – 11’ max. height
  - 2x4 @ 16” o/c – 15’ max. height
  - 2x6 @ 24” o/c – 16’ max. height
  - 2x6 @ 16” o/c – 20’ max. height
- .2 6’ WIDE OPENING
- 2x4 @ 24” o/c – 9’ max. height
  - 2x4 @ 16” o/c – 12’ max. height
  - 2x6 @ 24” o/c – 13’ max. height
  - 2x6 @ 16” o/c – 18’ max. height
- .3 8’ WIDE OPENING
- 2x4 @ 24” o/c – Not acceptable
  - 2x4 @ 16” o/c – 10’ max. height
  - 2x6 @ 24” o/c – 11’ max. height
  - 2x6 @ 16” o/c – 15’ max. height

For conditions that do not fall within the above, the Contractor shall

contact the Owner for direction and/or alternate methods of support.

- .5 Steel Stud Wall Framing: Following are maximum stud lengths recommended between supports using steel studs. They are based on a 1/50 hourly wind pressure of 8 psf as per the 2005 NBC plus a gust factor of 2 and an allowable maximum deflection of L/240.

<u>Stud Size</u>	<u>Maximum Height @ Stud Spacing</u>
3 <sup>5</sup> / <sub>8</sub> " x 0.036"	13.5' @ 12" o/c 12.3' @ 16" o/c 10.7' @ 24" o/c
3 <sup>5</sup> / <sub>8</sub> " x 0.048"	14.7' @ 12" o/c 13.4' @ 16" o/c 11.7' @ 24" o/c
3 <sup>5</sup> / <sub>8</sub> " x 0.060"	15.7' @ 12" o/c 14.3' @ 16" o/c 12.5' @ 24" o/c
6" x 0.036"	20.1' @ 12" o/c 18.3' @ 16" o/c 15.9' @ 24" o/c
6" x 0.048"	22.0' @ 12" o/c 20.0' @ 16" o/c 17.4' @ 24" o/c
6" x 0.060"	23.5' @ 12" o/c 21.4' @ 16" o/c 18.7' @ 24" o/c

Steel stud wall systems shall be installed as per manufacturer's recommendations for cross bracing, bottom and top tracks, fasteners, etc.

**3.3 Insulation**

- .1 The inside layer of insulation shall be laid horizontally and the outside layer shall be laid vertically to fit between the studs.
- .2 The remaining space behind each stud shall be filled with a strip of insulation 1<sup>1</sup>/<sub>2</sub>"x2" in cross-section, to ensure that the entire cavity is properly filled.

**3.4 Sheathing**

- .1 Fasten the <sup>3</sup>/<sub>8</sub>" ply sheathing to the outside face of wooden studs with 2<sup>1</sup>/<sub>2</sub>" nails at 6" o.c. at panel edges and 12" o.c. at intermediate studs.
- .2 Provide blocking at panel edges with 2" nominal blocking.

**3.5 Cladding**

- .1 Install approved cladding in accordance with manufacturer's specifications.

**3.6 Clean-up**

- .1 Repair and make good any areas disturbed or damaged by the operations.
- .2 Clean and trim areas disturbed by the operations and dispose of all surplus and waste materials off site.

----- **END** -----

## APPENDIX B

### Insulation Retrofit Drawings

Issued for Comment

- **Standard Drawings for Homes with Minimum 20" Eaves**

- Fig. 1 of 9 Typical Section
- Fig. 2 of 9 Base Details Above Grade
- Fig. 3 of 9 Base Details Below Grade
- Fig. 4 of 9 Sections
- Fig. 5 of 9 Gable End Section and Framing Support Around Window
- Fig. 6 of 9 Window Exterior Section and Floating Exterior Corner

- **Standard Drawings for 3- and 4-Storey Buildings**

- Fig. 7 of 9 Typical Section
- Fig. 8 of 9 Alternate Standoff Support Using Ledger
- Fig. 9 of 9 Splice Detail

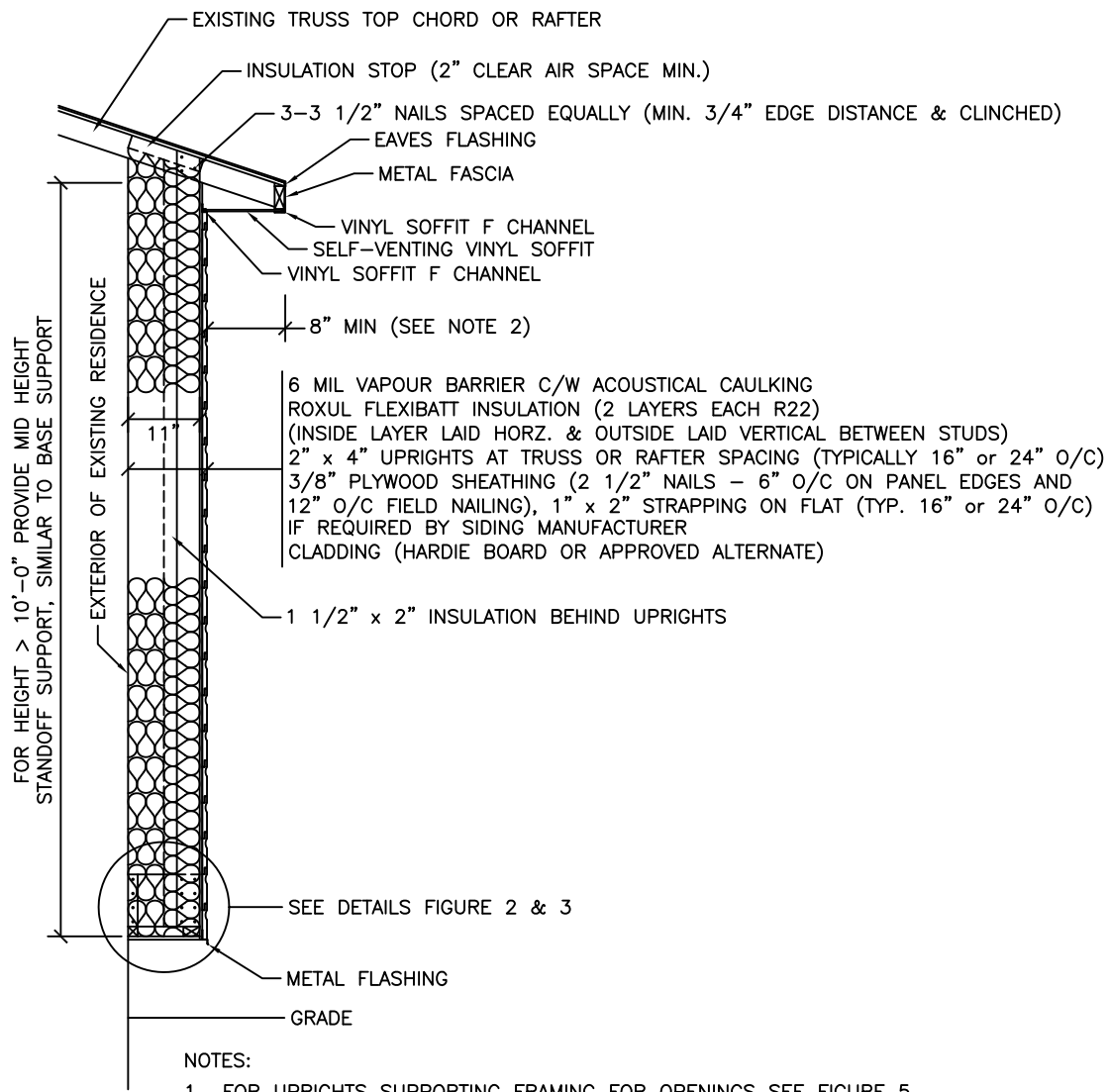

## TYPICAL SECTION

NOT TO SCALE

Issued for Comment

PROJECT  
INSULATION RETROFIT / STANDARD DRAWING FOR HOMES WITH MIN. 20" EAVES

PAGE  
FIGURE 1 OF 9

DRAWING TITLE  
TYPICAL SECTION

DATE DD MM YY  
20 07 09

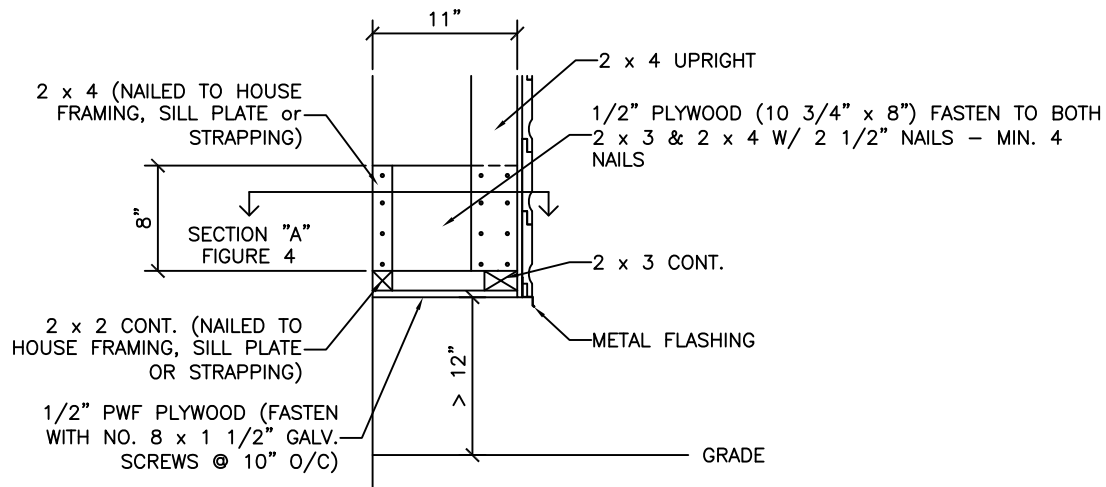

### BASE DETAIL 1 - > 12" ABOVE GRADE (TYP.)

NOT TO SCALE

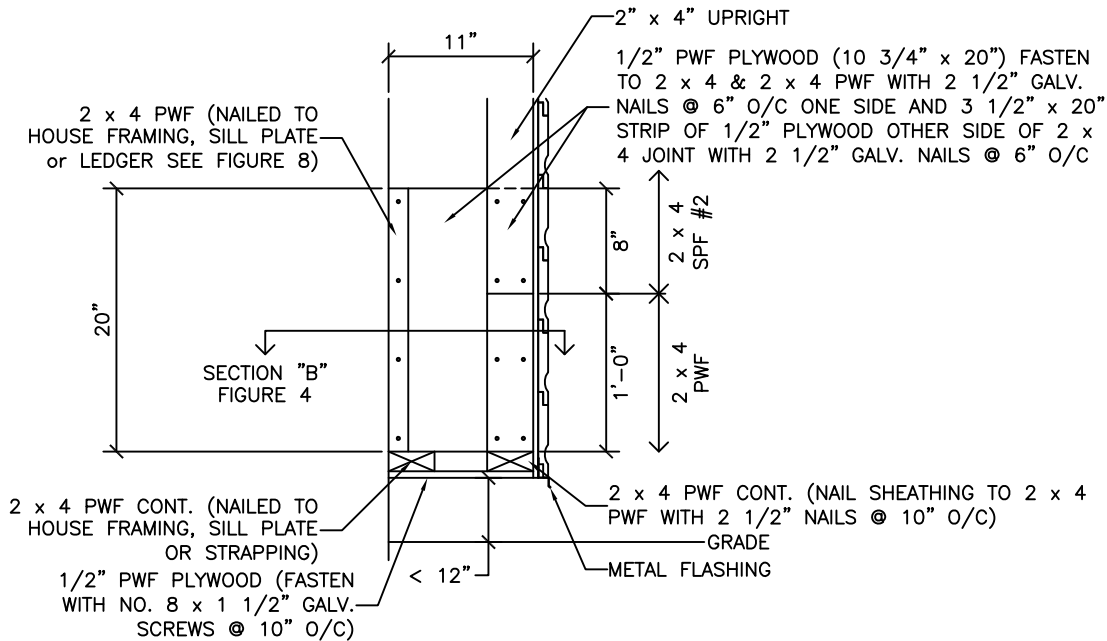

### BASE DETAIL 2 - < 12" ABOVE GRADE (TYP.)

NOT TO SCALE

Issued for Comment

PROJECT	INSULATION RETROFIT / STANDARD DRAWING FOR HOMES WITH MIN. 20" EAVES			PAGE	FIGURE 2 OF 9		
DRAWING TITLE	BASE DETAILS ABOVE GRADE			DATE	DD	MM	YY
					20	07	09



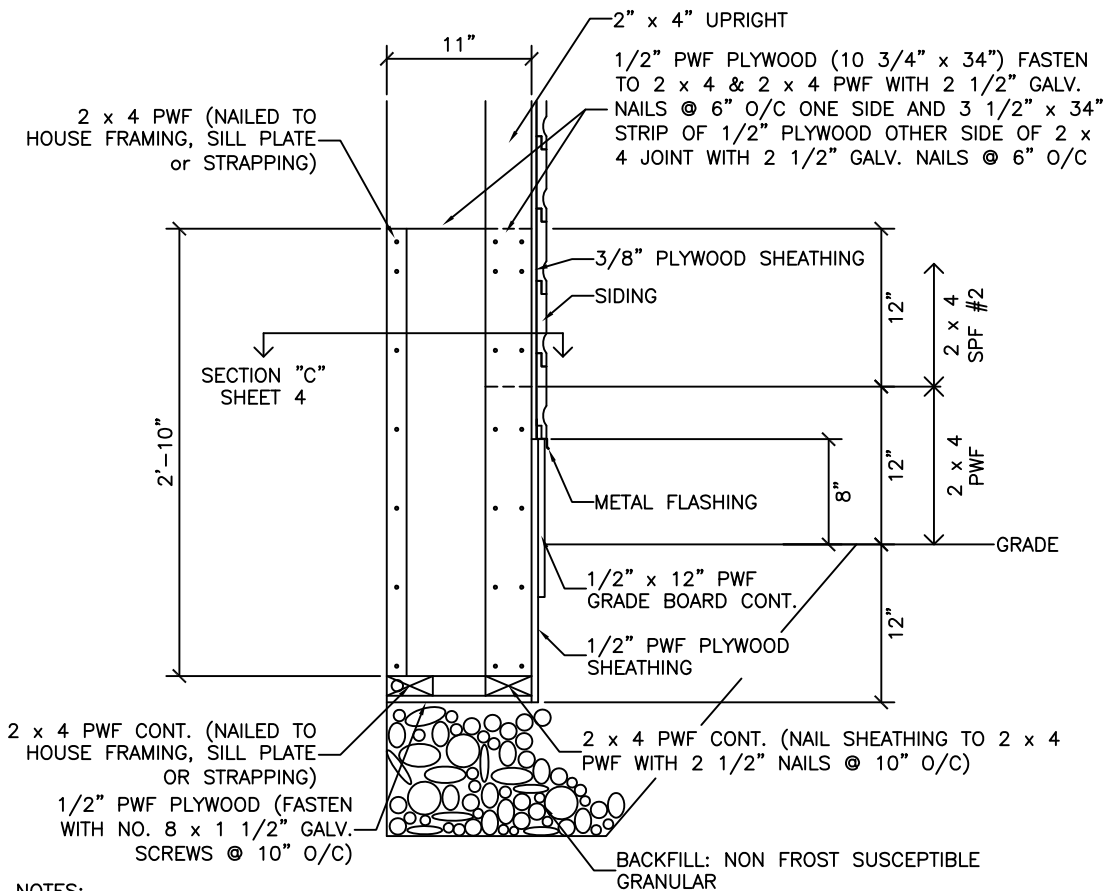

NOTES:  
 APPLY PRESERVATIVE TREATMENT TO ALL END CUTS.  
 BELOW GRADE PWF TREATMENT  
 FILL ALL NAIL HOLES, KNOTS, BLEMISHES AND JOINTS IN PWF PLYWOOD WITH SEALING COMPOUND (CGSB STANDARD 19-GP-14M BUTYL-POLYISOBUTYLENE POLYMER BASE, SOLVENT CURING). APPLY TWO COATS UNIFORMLY OF DAMPPROOFING CONFORMING TO CGSB-37-GP-2M, 37-GP-6Ma or 37-GP-16M, OVER ENTIRE AREAS BELOW GRADE.

## BASE DETAIL 3 - 12" BELOW GRADE (TYP.)

NOT TO SCALE

Issued for Comment

PROJECT	INSULATION RETROFIT / STANDARD DRAWING FOR HOMES WITH MIN. 20" EAVES			PAGE	FIGURE 3 OF 9		
DRAWING TITLE	BASE DETAILS BELOW GRADE			DATE	DD	MM	YY
					20	07	09

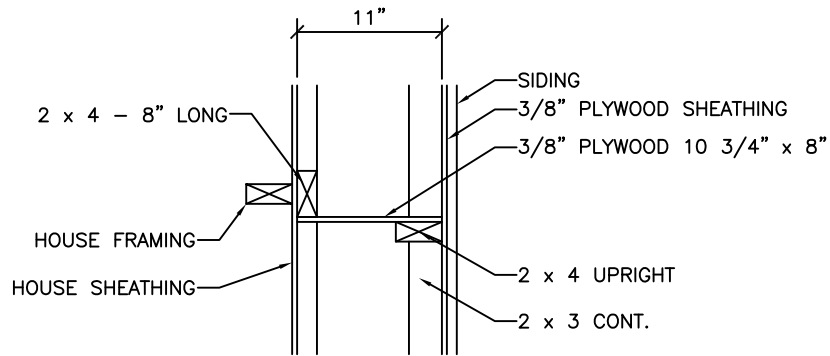

**SECTION "A"**

NOT TO SCALE

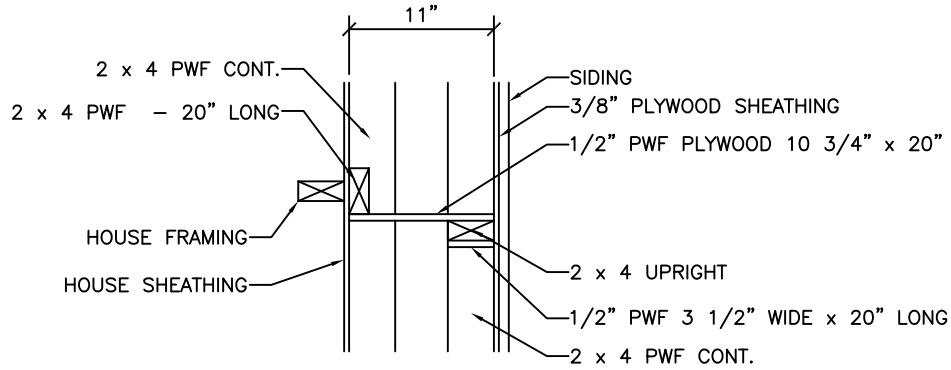

**SECTION "B"**

NOT TO SCALE

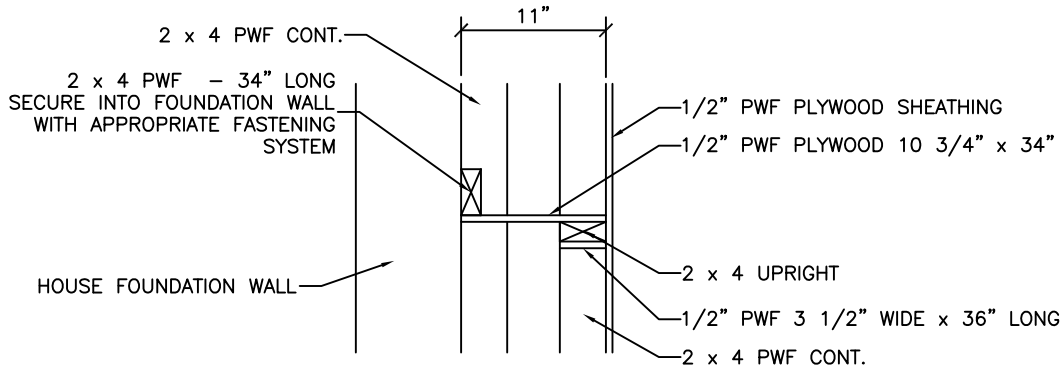

**SECTION "C"**

NOT TO SCALE

Issued for Comment

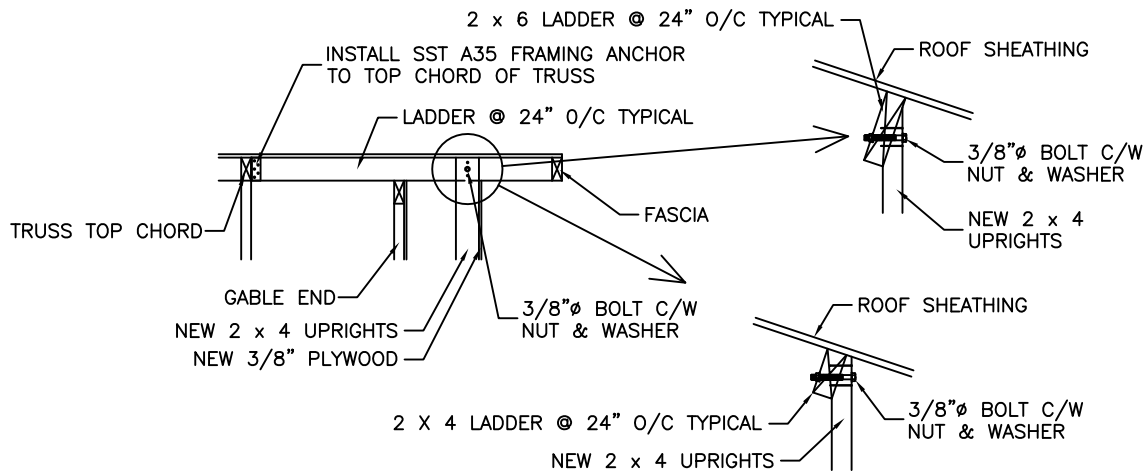

TEMPORARILY SECURE UPRIGHT WITH NAILS AND THEN ADD BOLT  
 FOR ALTERNATE CONNECTION SEE FIGURE 8

## GABLE END SUPPORT

NOT TO SCALE

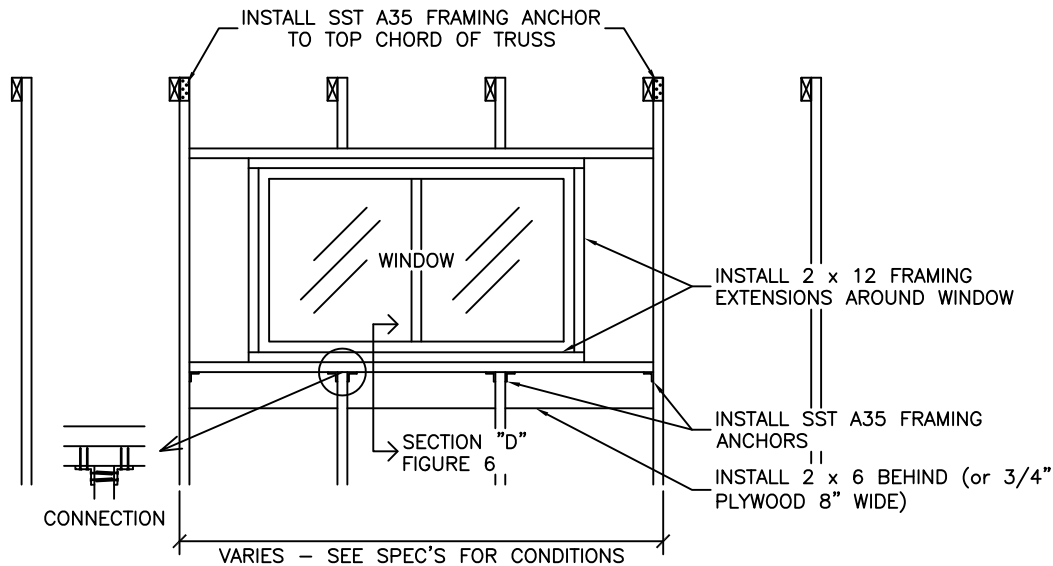

## FRAMING SUPPORT AROUND WINDOW

NOT TO SCALE

Issued for Comment

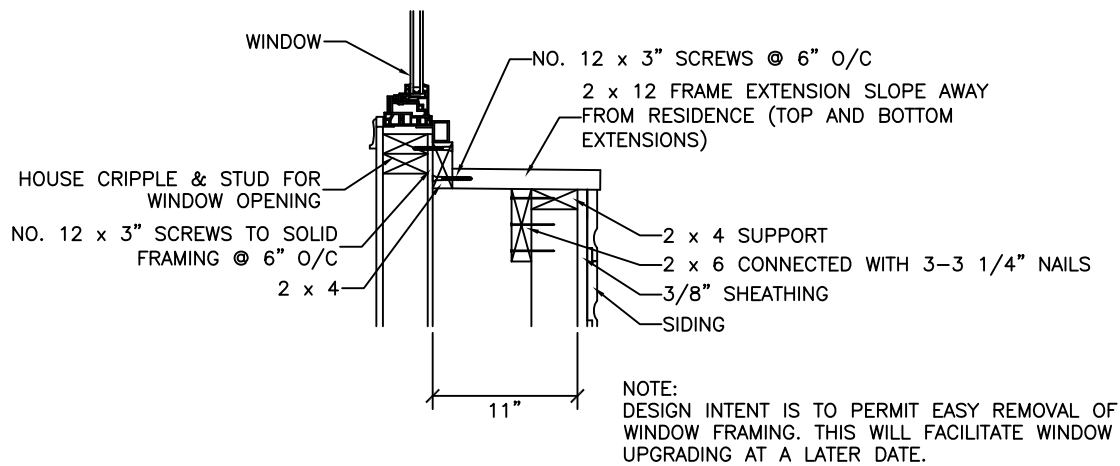

## WINDOW EXTENSION SECTION "D"

NOT TO SCALE

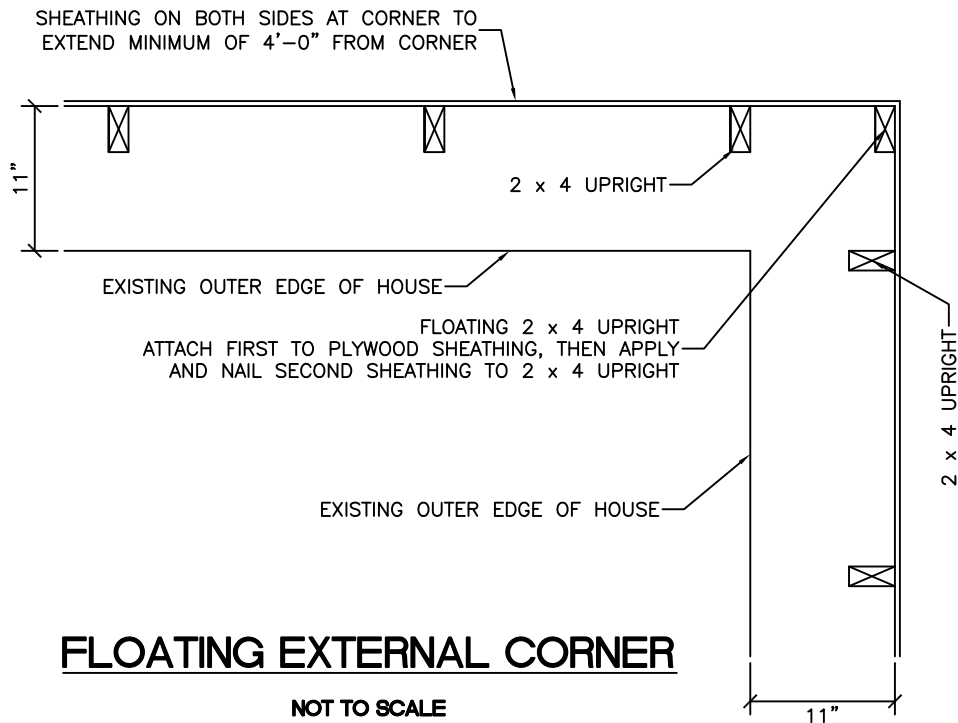

## FLOATING EXTERNAL CORNER

NOT TO SCALE

Issued for Comment

PROJECT	INSULATION RETROFIT / STANDARD DRAWING FOR HOMES WITH MIN. 20" EAVES			PAGE	FIGURE 6 OF 9		
DRAWING TITLE	WINDOW EXTENSION SECTION AND FLOATING EXTERNAL CORNER			DATE	DD	MM	YY
					20	07	05

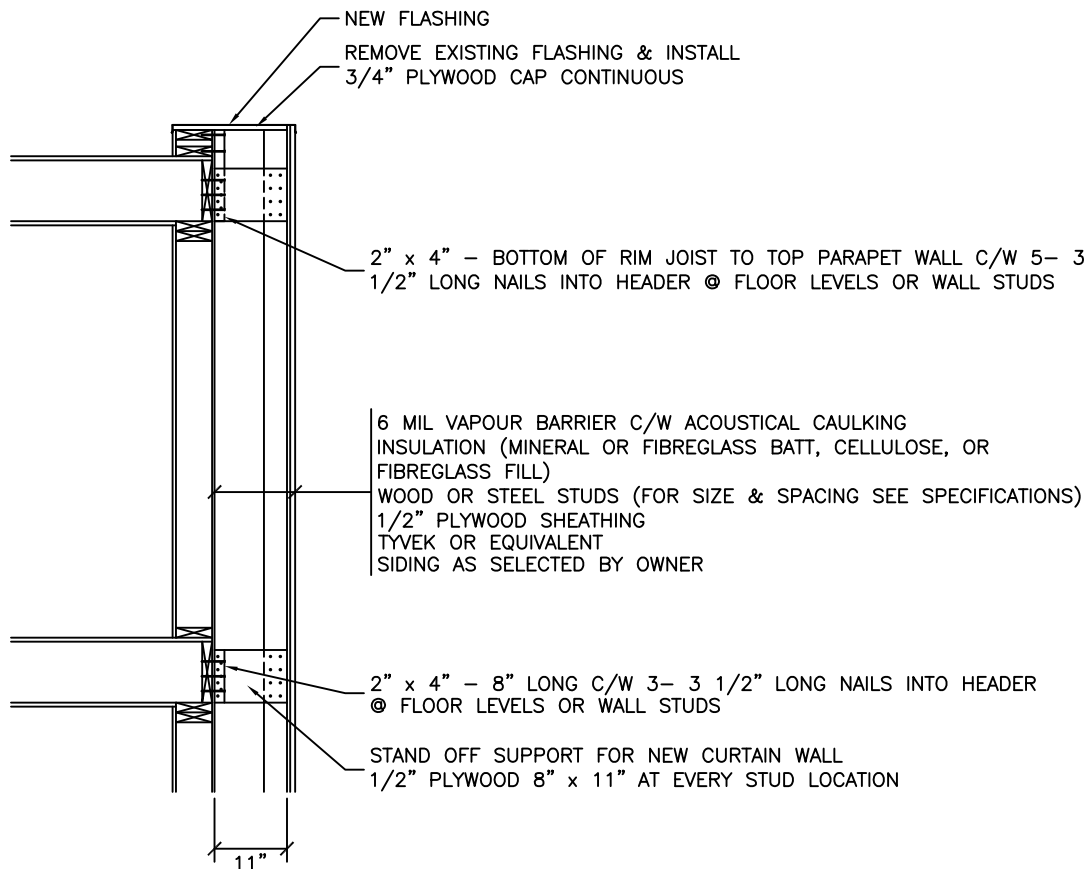

## TYPICAL WALL SECTION

NOT TO SCALE

Issued for Comment

PROJECT  
 INSULATION RETROFIT - 3 AND 4 STOREY BUILDINGS

PAGE  
 FIGURE 7 OF 9

DRAWING TITLE  
 TYPICAL WALL SECTION

DATE DD MM YY  
 20 07 09

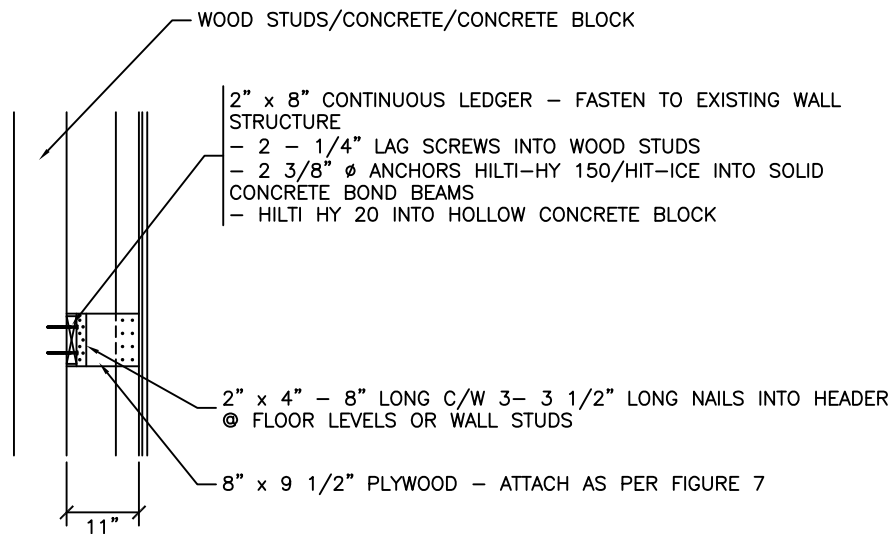

## ALTERNATIVE STAND OFF SUPPORT USING LEDGER

NOT TO SCALE

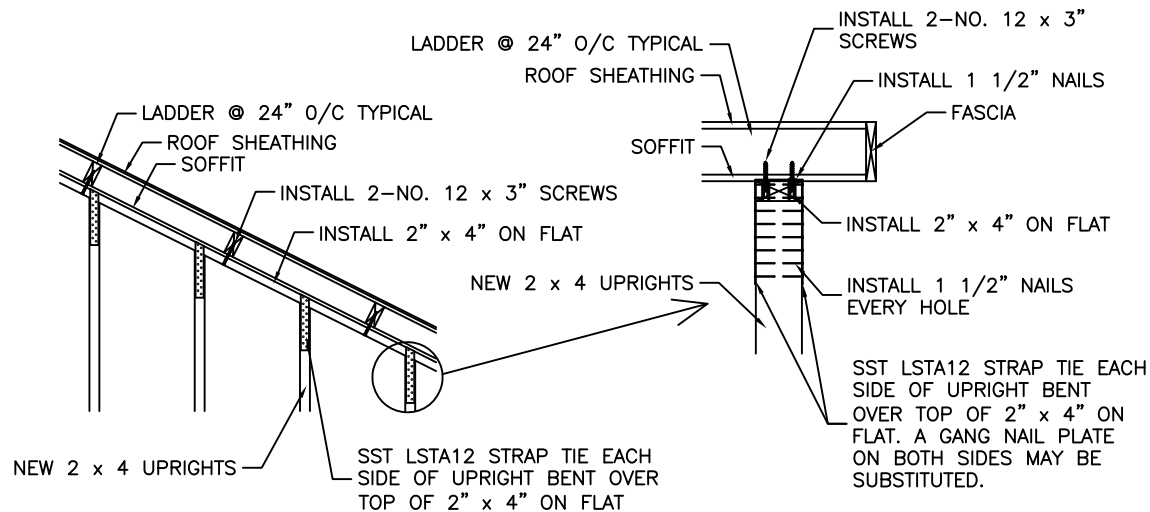

## ALTERNATIVE GABLE END SUPPORT

NOT TO SCALE

Issued for Comment

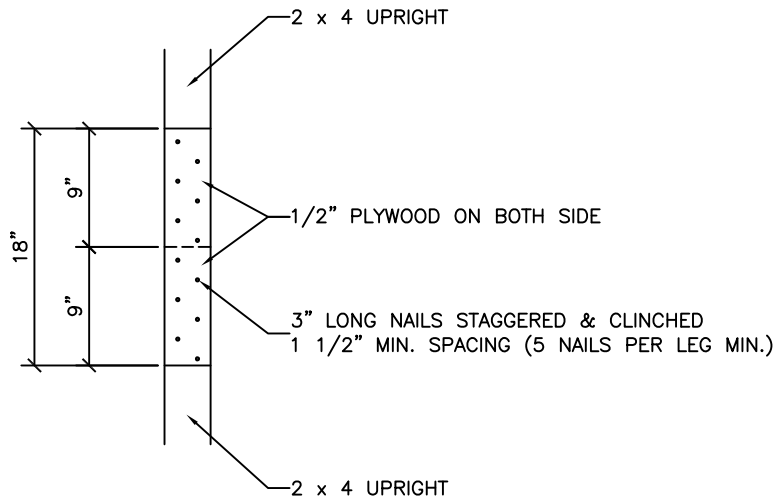

## SPLICE DETAIL

NOT TO SCALE

Issued for Comment

PROJECT  
INSULATION RETROFIT / STANDARD DRAWING FOR HOMES WITH MIN. 20" EAVES

PAGE  
FIGURE 9 OF 9

DRAWING TITLE  
SPLICE DETAIL

DATE	DD	MM	YY
	20	07	09